

SET TEMPERATURE

1. Press **UP** or **DOWN** buttons to the desired temperature. The setting will automatically lock after three seconds..

BASELINE DRYING TEMPERATURES

The following are baseline settings for some of the most popular filaments tested under normal conditions at our facility. Varying environmental conditions in your area and/or the use of more exotic materials may require some fine tuning for maximum efficiency.

SETTING PID CONTROLLER ABOVE 80° C IS NOT RECOMMENDED. DOING SO MAY CAUSE FILAMENT TO MELT IN THE DRYER AND CAUSE A CLOG.

ABS	50-60° C
ASA	60-65° C
NYLON	65-70° C
PETG	65-70° C
PLA	40-50° C
POLYPROPELENE	50-55° C
POLYCARBONATE	65-70° C
TPU/TPE	50-55° C

UNCLOGGING YOUR DRYER

1. Turn dryer off and disconnect from power source. **ALLOW TO COOL COMPLETELY.**
2. Remove Bowden tube from rear of dryer.
3. Using the provided 2.4mm drill bit and a power drill, slowly ream out the clog from rear of dryer.

NOTE: Depending on the severity of the clog, it may be necessary to remove the lid and clear excess material from the heater cooling vents.

4. Reassemble and restart.

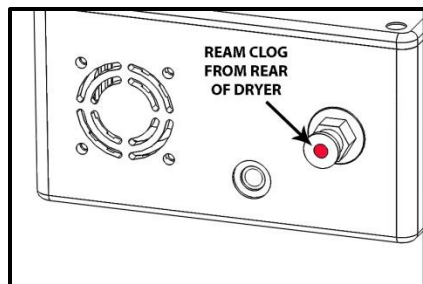

FREE DOWNLOADS For printable mount brackets and other handy tools and accessories. Visit our website at <http://thordsen3d.com/downloads/>

CUSTOMER FEEDBACK

Customer feedback is very important to us. In true maker spirit, we encourage everyone to tinker with and share designs, temperature settings, and whatever else that makes our system work to maximum efficiency. Submit feedback to: thordsen3d@gmail.com

SATISFACTION GUARANTEE Thordsen3D is so confident in the quality and craftsmanship of our Inline Filament Dryers that we offer an unconditional 30 day satisfaction guarantee and a one year limited repair/replacement warranty on material defects and workmanship.

For more information, visit our website at: <http://thordsen3d.com/guarantee/>



IFD-175S INLINE FILAMENT DRYER QUICK START GUIDE

INTRODUCTION

Maintaining 3D printer filament dryness can be tricky, time consuming, and wasteful.

Thordsen3D Filament dryer systems are plug and play units designed to be adaptable to virtually any hobbyist or professional grade 3D printer on the market today. They effectively extract 80% to 100% of ambient moisture from your 1.75mm filament as it is being fed directly into your 3D printer's hot end.

It is very effective as a standalone filament drying solution or can be a great addition to other drying solutions under more extreme environmental conditions like baking, desiccant drying, or a dehydrator.

The PID controller is very easy to program and the PV output is pre-calibrated at our facility to plus or minus .5° C, providing consistent moisture control of your filament.

The end result is perfect bubble free prints no matter what material, print duration, or environmental conditions.

Copyright 2019 Thordsen Customs LLC. All right reserved

REV 06 4/24//2019

DISCLAIMERS



UNPACKING AND INSPECTION

Inspect all component parts for shipping damage or defects. If your unit is damaged, **DO NOT USE**. Please contact Thordsen3D Tech Support immediately at 530-748-2288. (Minor marring or surface irregularities in the molded case are not considered defects.)

PACKAGE CONTENTS

- | | | |
|---------------------------------|----------------------|---------------------|
| 1) IFD-175S Filament Dryer | 1) Power Cord | 1) Thordsen3D Decal |
| 1) Bowden Tube 40" (100cm) Long | 1) Quick Start Guide | |
| 1) 12 Volt 5A Power Supply | 1) 2.4mm drill bit | |

ASSEMBLY

1. Insert Bowden tube into rear of dryer. Tube must be fully inserted for the filament to exit smoothly.
 2. Insert opposite end of bowden tube into printer head.
 3. Adjust length of tube if needed.
- NOTE: Be sure to allow enough slack for hot end to move freely without kinking.
3. Connect power supply to dryer control box and wall socket.

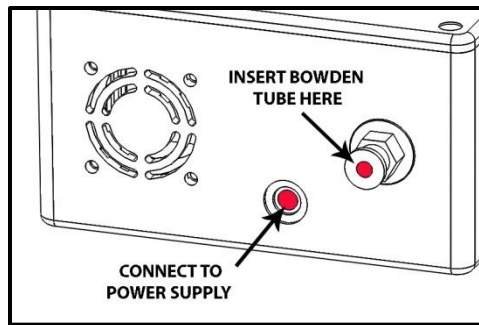

START UP

WARNING THE PID CONTROLLER CAN SPIKE UP TO PLUS 15°C DURING CALIBRATION.

DO NOT feed filament through dryer until calibration procedure is complete or it may melt in the heater unit. If this should occur, please read the "UNCLOGGING YOUR DRYER" section.

1. Place dryer on a flat surface to allow proper clearance for bottom cooling vents.
2. Flip rocker switch to the on position and allow PID controller to calibrate itself. This can take 2 to 4 minutes depending on your previously saved temperature setting.
3. Feed filament through dryer and into print head.
4. If wet material is used, Run a minimum of 40" (100cm) of filament through the hot end to insure that your print starts with dry material. (If material is new or removed from a passive dryer, this step may not be necessary.)

CONTROL PANEL FUNCTIONS

- PID CONTROLLER MEASURES TEMPERATURE IN CELCIUS.
- SV INPUT IS FACTORY PRESET AT 60° C.
- PV OUTPUT IS FACTORY PRESET TO + / - .5° C.
- CHANGING PV OUTPUT SETTINGS IS NOT RECOMMENDED
- ADVANCED USERS, PV OUTPUT SETTINGS FLOWCHART IS AVAILABLE ON OUR WEBSITE AT: <http://thordsen3d.com/tech-support/>

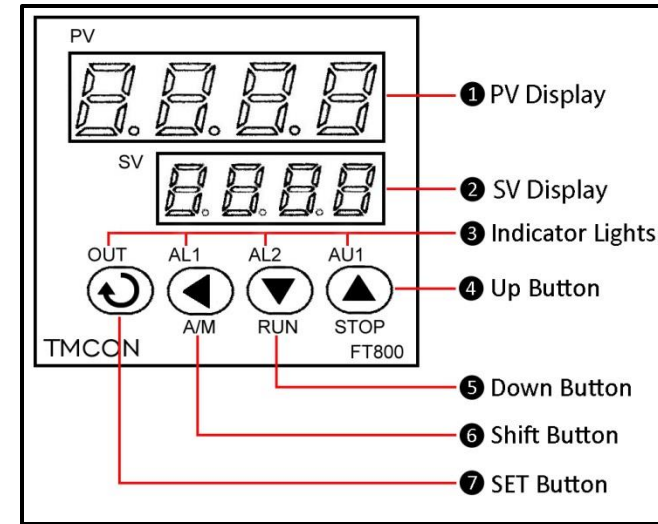

- 1 **PV Display:** Displays current temperature of filament warmer.
- 2 **SV Display:** Displays user set tperature.
- 3 **Indicator Lights:**
 - OUT: Control output
 - AL1, AL2: Alarms (non functional)
 - AU1: Auxillary output (non functional)
- 4 **Up Button:** Increase Value.
- 5 **Down Button:** Decrease Value.
- 6 **Shift Button:** Use to scroll through advanced settings menu. (not recommended)
- 7 **Set Button:** Locks settings in memory and saves when dryer is turned off.